

# Fold-up!

FLEXIBLE FURNITURE FOR POP-UP STORES AND MORE



اومداسح  
صانعتو استجر



Jemanden eine Freude machen

K

# Pop-up-Systems

ONE FITTING FOR ALL NEEDS

نظام موحد لجميع الاحتياجات

## Start-up, Pop-up, Fold-up!

Whether for the revitalisation of city centres by filling empty stands, for the temporary staging of seasonal goods in aisle areas or as exhibition furniture: Fold-up! makes it possible.

No piece of furniture is as flexible as Fold-up! Thanks to its modular design, the fitting provides the perfect stage for products of all kinds, regardless of their dimensions and product group.

Combine the modules as you like and create rooms out of nothing. The possibilities are limitless, from product racks for fashion, food or as checkout tables.

With different design options for the frames, such as powder coating or chrome, as well as the insert compartments, we realise individual solutions for your requirements.

Our Fold-up! sets offer solutions for the most common uses. If required, you can order all components separately and combine as desired.

البداية، الأنظمة المنبثقة، الأرفف القابلة للطي!

سواء لتنشيط مراكز المدينة عن طريق ملء المدرجات الفارغة، أو للتدريج المؤقت للبضائع الموسمية في ممرات المدينة أو كأثاث للمعارض: الأرفف القابلة للطي يجعل ذلك ممكناً. لا توجد قطعة أثاث مرنة مثل الأرفف القابلة للطي! بفضل تصميمه المعياري، يوفر المرحلة المثالية والمناسبة للمنتجات من جميع الأنواع، بغض النظر عن الأبعاد ومجموعة المنتج الذي ينتمي إليه.

يمكنك الجمع بين الوحدات كما ترغب و خلق غرف من لا شيء الى رفوف منتجات الأزياء و الغذاء و جداول الخروج.

مع خيارات التصميم المختلفة للإطارات، مثل مسحوق الطلاء أو الكروم، وكذلك مقصورات الادراج، نحن ندرك ونوجد حلول فريدة خاصة باحتياجاتك.

الأرفف القابلة للطي تقدم مجموعة حلول للاستخدام الأكثر شيوعاً. إذا لزم الأمر يمكنك طلب جميع المكونات بشكل منفصل والجمع بينهم على النحو المرغوب به.

## ADVANTAGES

## المزايا

— Various coatings and surfaces possible

— تواجد مختلف أنواع الطلاء و الاسطح

— Unbeatable price/performance ratio

— بأداة ونسبة سعر لانهزم

— Specially developed for temporary use

— وضعت خصيصاً للاستخدام فترة مؤقتة

— Reacts flexibly to assortment and product size

— يتفاعل بمرونة لتشكيل حجم المنتج و شكله

## SIMPLY BUILT UP بُنيت ببساطة

### Ⓔ Start-up, Pop-up, Fold-up!

البداية، الأنظمة المنبثقة، الأرفف القابلة للطي!

Fold-up! is designed for easy self-assembly. In just a few minutes, you can screw together the individual basic frameworks and insert the shelves of your choice.

الأرفف القابلة للطي مصممة لسهولة التجميع الذاتي. في بضع دقائق يمكنك جمع القطع الأساسية الفردية وإدخال الرفوف من اختيارك.

This efficient option allows you to modify to suit product pressure and expand or quickly stow the shelves as required.

يتيح لك هذا الخيار الفعال التحكم بالضغط و المساحة والسرعة الخاصة بالنتم على حسب.



1

The base of the shelf is a simple basic module.

قاعدة الجرف هي الوحدة الأساسية البسيطة.



2

2 x basic module is screwed together and thus to a system.

اثنان من الوحدات الأساسية مترابطان معاً مما يخلق نظام.



3

The system can be adapted with product carriers or add-ons. The result is a finished shelf.

يمكن تكيف النظام مع ناقلات المنتج أو إضافات. وسيتمهي كرف.



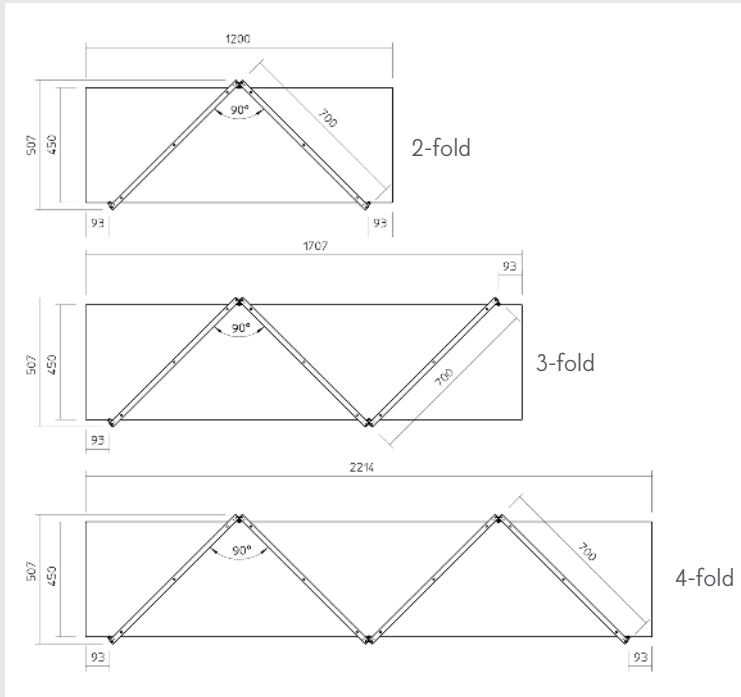

## ASSEMBLY STRUCTURE

A Fold-up! shelf consists of two to four basic modules. For all three combinations, suitable shelves of various dimensions are available. As required, add-ons such as rear walls, information boards, clothes hangers and much more can be fitted. See modules pages 8/9

## هيكل التجميع

الأرفف القابلة للطي يتكون الرف من ٢ الى ٤ وحدات أساسية. تتواجد أرفف مختلفة الأبعاد ومناسبة لجميع المجموعات. حسب الرغبة، ويمكن إضافة الجدران الخلفية، لوحة المعلومات، الشماعات وأكثر بكثير مما يمكن تركيبه. أنظر الى الصفحة ٩/٨.

Material of the product carriers and shelving units available in spruce three-layer. Other decors on request.

Spruce nature

Spruce nature lacquered

Frame powder-coated in 3 standard colours available. Other decors on request.

ALL 9995

RAL 9005

RAL 9010

Add-ons such as perforated sheeting, hooks, rods are simple to mount.

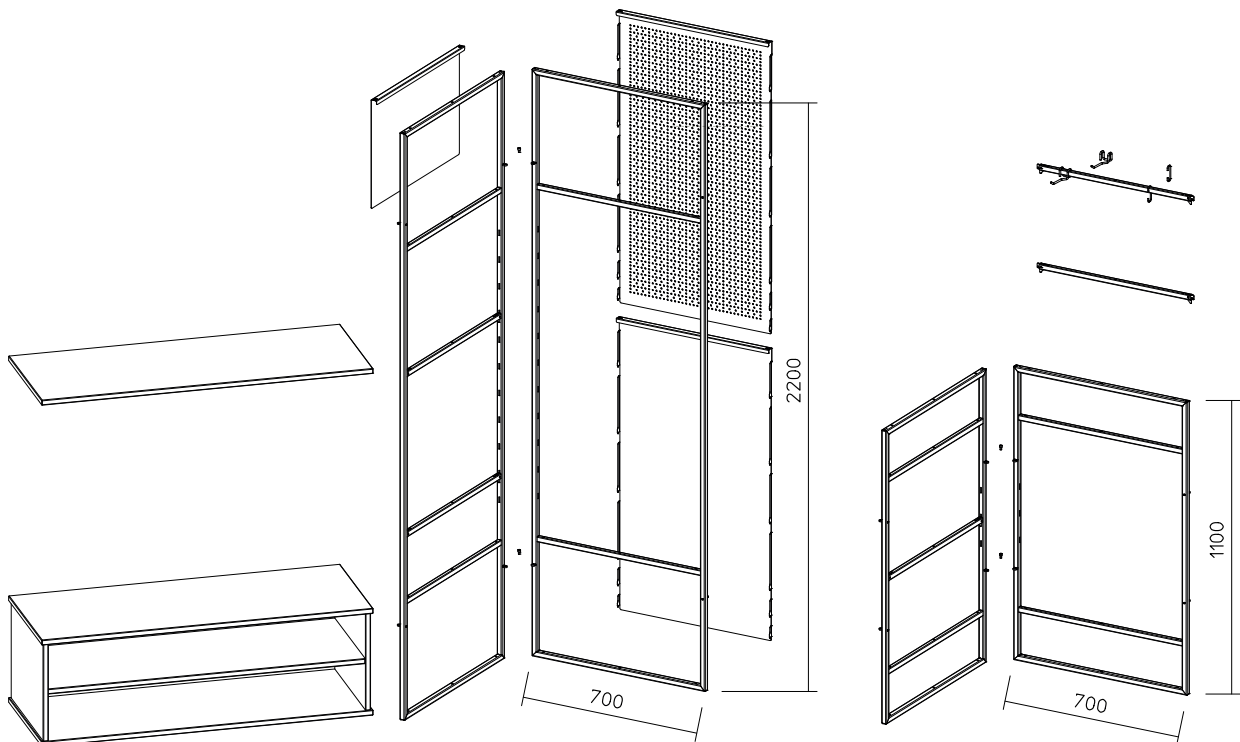

# Fold-up! Sets\*

## SET1 Classic 2-fold

No. 6112993

2 x Basic Module



## SET2 Classic 3-fold

No. 6112994

3 x Basic Module



## SET3 Classic 4-fold

No. 6112995

4 x Basic Module

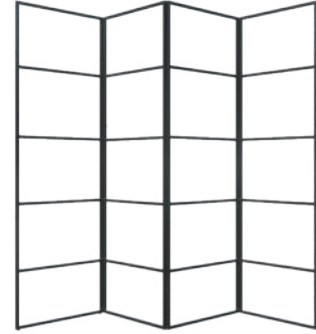

## SET4 Check-out

No. 6112996

2 x Basic Module Small  
1 x Cash Desk (lockable)



## SET5 Check-out Pro

No. 6112997

2 x Basic Module  
1 x Cash Desk (lockable)



Use the well thought-out possibilities that we deliver to you in pre-configured sets. For every application, there is an optimal solution.

الاحتمالات مدروسة جيداً، وذلك من خلال المرحلة التي نقدمها لك في تكوينها مسبقاً، لكل تطبيق هناك حل مثالي.

## SET6 Small

No. 6112998

4 x Basic Module Small  
3 x Shelf 4-fold



## SET7 Small Pro

No. 6112999

4 x Basic Module Small  
2 x Shelf 4-fold  
1 x Frame Unit 4-fold



## SET8 Small Multi

No. 6113000

8 x Basic Module Small  
2 x Shelf 4-fold  
1 x Tabletop 4-fold



\* Including Assembly tool with manual

### SET9 Info

No. 6113001  
3 x Basic Module  
4 x Back Panel perforated  
2 x Back Panel flat



### SET10 Shelves

No. 6113002  
2 x Basic Module  
4 x Shelf 2-fold  
2 x Info Panel



### SET11 Shelves Pro

No. 6113003  
3 x Basic Module  
4 x Shelf 3-fold  
2 x Info Panel



### SET12 Shelves Extended

No. 6113004  
4 x Basic Module  
4 x Shelf 4-fold  
4 x Info Panel



### SET13 Hook

No. 6113005  
4 x Basic Module  
12 x C-Hook  
4 x Info Panel



### SET14 Hook Pro

No. 6113006  
4 x Basic Module  
2 x Clothes Rail



### SET15 Hook Body

No. 6113007  
4 x Basic Module  
1 x Shelves Unit 4-fold  
2 x Info Panel



### SET16 Hook Multi

No. 6113008  
4 x Basic Module  
1 x Clothes Rail  
2 x Shelf 2-fold  
1 x Shelves Unit 2-fold



### SET17 Fruit & Vegetables







No. 6113009  
4 x Basic Module  
2 x Info Panel  
3 x Diagonal presenter 4-fold  
12 x C-Hook



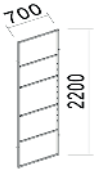
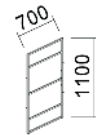

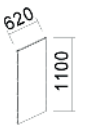
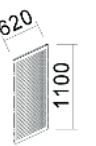
# Fold-up! Add-ons

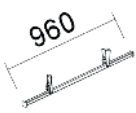

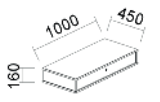
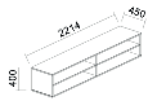
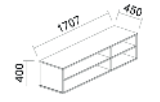
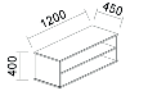

STRAIGHT-FORWARD CONSTRUCTION

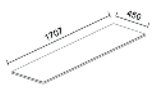
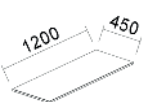
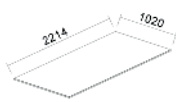
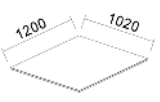
اعمال البناء المباشرة

| Designation  | Item Number | Design  |
|--|-------------|---|
| Basic Module<br>2200x700                                   | 6110780     |    |
| Basic Module Small<br>1100x700                             | 6110781     |    |
| Protective profile for frame (self-adhesive)<br>657        | 481400-14   |  |
| Back Panel flat<br>1100x620                                | 6110752     |  |
| Back Panel perforated<br>1100x620                          | 6110753     |  |
| Info Panel 410x620   | 6110754     |  |
| Clothes Rail with Straps 960                               | 6110779     |  |
| Protective profile for Clothes Rail (self-adhesive)<br>954 | 481400-13   |  |

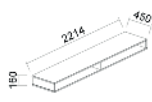
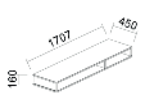
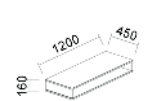
| Designation                        | Item Number | Design  |
|------------------------------------|-------------|---|
| Cash Desk<br>1000x450x160          | 6110877     |    |
| Shelve Unit 4-fold<br>2214x450x400 | 6113036     |    |
| Shelve Unit 3-fold<br>1707x450x400 | 6113035     |   |
| Shelve Unit 2-fold<br>1200x450x400 | 6113034     |  |
| Shelf 4-fold<br>2214x450           | 6110979     |  |
| Shelf 3-fold<br>1707x450           | 6113031     |  |
| Shelf 2-fold<br>1200x450           | 6110987     |  |
| Tabletop 4-fold<br>2214x1020       | 6110991     |  |
| Tabletop 2-fold<br>1200x1020       | 6113037     |  |

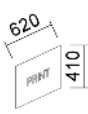

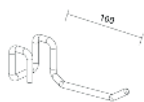
| Designation   | Item Number | Design  |
|---|-------------|---|
| Frame Unit 4-fold<br>2214x450x160<br>(no back wall) | 6113106     |    |
| Frame Unit 3-fold<br>1707x450x160<br>(no back wall) | 6113105     |    |
| Frame Unit 2-fold<br>1200x450x160<br>(no back wall) | 6113104     |    |
| Assembly tool with<br>manual                        | 6110785     |  |
| Print Magnetic Board<br>2200x620                    | 6113026     |  |
| Print Magnetic Board<br>410x620                     | 6113021     |  |
| C-Hook<br>65  | 6113193     |  |
| Hanging Rail<br>100                                 | 5002801     |  |

## START-UP, POP-UP, FOLD-UP!

Order the sophisticated sets,  
or configure your store individually  
using Add-ons.

ترتيب مجموعة متطورة، أو تكوين منطقة مبيعات  
منبثقة بشكل فردي باستخدام  
الوظائف الإضافية

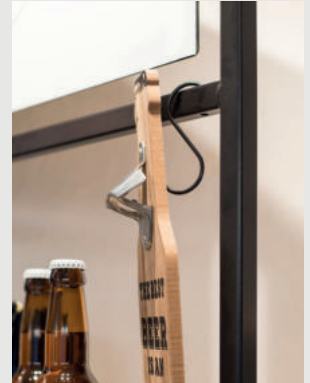

INSIGHT

# Fold-up System

EXPERIENCE THE VARIETY

اعمال البناء المباشرة



LOCATION Dubai EXPO2020





We produce

# shop equipment.

Shelving Systems

Freestanding Systems

Bespoke Furniture

POP

Warehouse Racking Systems

## SALES PARTNER

Store Makers Interiors L.L.C, Unit 5, 48th Street,  
Dubai Investments Park (DIP) 2, P.O. Box 182774, Dubai, UAE

*store makers*  
Middle East

Powered by  
umdash

GET IN TOUCH



[info@storemakers-me.com](mailto:info@storemakers-me.com)